



# VENTO CO<sub>2</sub>

*\_Remote CO<sub>2</sub> Multideck*

## Proven Quality for CO<sub>2</sub> Systems

VENTO CO<sub>2</sub> is specifically designed for use in remote CO<sub>2</sub> systems and impresses with maximum display area and a wide range of variants. The VENTO product family can be optimally tailored to the needs of your sales space.



### VISUAL MERCHANDISING

VENTO CO<sub>2</sub> comprises a fully flexible and connectable refrigerated shelf family designed for high product load. With a wide range of different door configurations (sliding glass, swing PET or glass) and various accessories, the VENTO CO<sub>2</sub> models are well-suited for optimal product presentation.



### DIVERSE PRODUCT DISPLAY

Due to its wide temperature range, this refrigerator is suitable for presenting a variety of product groups, including dairy products, fish, meat, beverages, delicatessen items, ready-made meals, fruits, and vegetables. Temperature stability is ensured through tested and automatic defrosting.



### FLEXIBLE INSTALLATION

A quick installation is possible due to smart features such as the feet height adjustment from the inside of the cabinet. A variety of available controllers such as Wurm, Danfoss and Carel ensure best possible integration into your system.



### ONE-STOP-SOLUTION

AHT doesn't just supply the refrigerated shelf; we deliver the entire CO<sub>2</sub> system tailored to your requirements.



### ENVIRONMENT AND CLIMATE

VENTO CO<sub>2</sub> utilizes the natural refrigerant CO<sub>2</sub> (R774), which is classified with a low Global Warming Potential (GWP) of 1. Consequently, it is particularly environmentally friendly.



### COMPATIBLE WITH THE ACTIVE MONITORING SYSTEM

Our Active Monitoring System (AMS) allows us to detect problems before you notice them. As an essential add-on to all AHT products, the AMS makes it much easier for you to manage and monitor the AHT cooling systems in your stores. Our products are also compatible with other systems.

## INDIVIDUAL BRANDING

VENTO refrigerated cabinets can be individually adapted to the store design. A wide range of colours allows the best possible integration.



## TEMPERATURE RANGES

H1 – Chilled vegetables & fruits	+1 °C to +10 °C
M2 – Dairy products	-1 °C to +7 °C
M1 – Dairy products, colder	-1 °C to +5 °C
M0 – Dairy products, special temp.	-1 °C to +4 °C
S1* – Meat & fish	-1 °C to +2 °C

\* with GD models only

## *USPs*

### *INSTALLATION OPTIONS*

Thanks to the variety of models, various installation possibilities can be offered. Whether it's the classic in-line setup, a suitable corner installation, an island arrangement, or a double row – with VENTO CO<sub>2</sub>, you have the choice.

### *HEAT RECOVERY*

To become even more energy-efficient, the waste heat from the cooling process can be utilized for heating water, business premises, or other spaces. Thanks to AHT's extensive product portfolio, we can provide a complete solution tailored to the specific requirements of the market.



# Versions



Stand-alone



In-line



Block



Island\*

## CONFIGURATIONS

Stand-alone



In-line



Block



Island\*



\_ optionally with end cabinets on both sides

\_ specific installation per type on request

\*except H8 models



## VENTO CO<sub>2</sub>

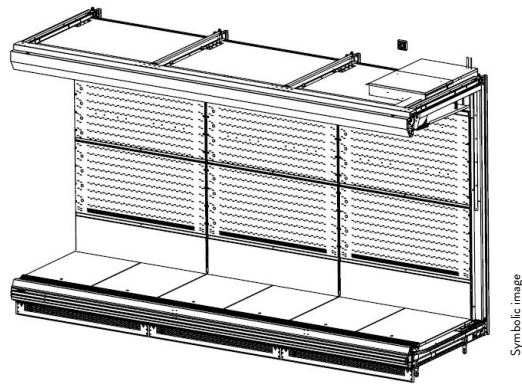
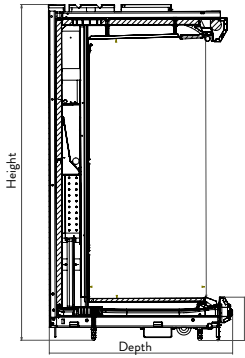

### DIMENSIONS

VENTO CO <sub>2</sub>		Width	Height	Depth	Shelf depth
LS6 GD EC	mm	1.780	2.200	951	600
LS6 GD	mm	2.500	2.200	951	600
LS6 GD	mm	3.750	2.200	951	600
HS6 GD EC	mm	1.780	2.400	951	600
HS6 GD	mm	2.500	2.400	951	600
HS6 GD	mm	3.750	2.400	951	600
L8	mm	2.500	2.200	1.262	800
L8	mm	3.750	2.200	1.262	800
L8 GD	mm	2.500	2.200	1.262	800
L8 GD	mm	3.750	2.200	1.262	800
H8	mm	2.500	2.400	1.262	800
H8	mm	3.750	2.400	1.262	800
H8 GD	mm	2.500	2.400	1.262	800
H8 GD	mm	3.750	2.400	1.262	800

GD = with glass doors only; Number of doors: EC 178/178 – 3 doors, 250 – 4 doors, 375 – 6 doors., irrespective of type  
Further data can be found in the data sheet of the Ecodesign Directive

Subject to technical changes; errors and omissions excepted. Version: 01/2024

**AHT**   
a member of **DAIKIN** group

AHT Cooling Systems GmbH

Werksgasse 57  
8786 Rottenmann | Austria  
p. +43 3614 24 51-0  
sales@aht.at  
www.aht.at