



RIO S & RIO H

_Freezer cabinet. Plug-in installation

USPs

PERFECT FOR CHILDREN

Due to the reduced height ice cream is easily accessible even for children. The glass sliding lids are opening and closing smoothly.

INDEPENDENT POSITIONING

RIO can be served from both sides and is the ideal solution for every area because of different size variants.

TEMPERATURE RANGES

Freezing -14 °C to -23 °C

Scooping ice cream -6 °C to -23 °C



Versatile and seductive.

RIO models are the perfect choice for selling ice cream in various places. The broad variety of sizes ensure perfect integration in any store layout and boost your sales.



VISUAL MERCHANDISING

RIO is displaying the goods perfectly to customers due to its low height it can easily be looked into. The smooth-running, two-part, straight sliding glass lid with the proven, patented, sprayed one-piece AHT cover frame ensures easy goods removal. The brilliant LED interior lighting presents your goods in best conditions.



LOW COSTS

The proven AHT quality guarantees you a trouble-free longevity. RIO is delivered in a robust packaging accessible for forklifts.



ENVIRONMENT AND CLIMATE

RIO is completely free of CFCs and HFCs and runs with the ecologically harmless and natural refrigerant propane (R290). R290 has one of the lowest GWPs (global warming potential) on the market.



HIGH ENERGY SAVINGS

RIO scores with low energy consumption through reinforced insulation (72 mm). In addition the new optimized fan allows 0.5 kWh energy saving per day.



MULTIFUNCTIONAL PURPOSE

With the same height and depth RIO is available in different lengths. The inner container of white pre-painted and galvanized sheet metal harmonizes with the one-piece plastic frame perfectly. RIO specially scores with the adjustable thermostat and the outer skin condenser. Pollution and maintenance is therefore a thing of the past.



INTELLIGENT INSTALLATION

Thanks to the plug-in installation, RIO is immediately ready for use. With RIO you get a team player who also works with other AHT cooling and freezing units.



INDIVIDUAL BRANDING

AHT cooling units are constructed individually: Using our template, you create the design, then we apply it directly during production.



RIO H 68



RIO H 100



RIO H 125



RIO S 68



RIO S 100



RIO S 125



RIO H 150



RIO H 175



RIO S 150



RIO S 175

ACCESSORIES

- _Temperature display: outer (front wall) and/or indoor thermometer
- _Condensate drain
- _robust castors (can be braked)
- _Interior light / LED light for RIO S
- _Light canopy
- _Energy-saving fan
- _Insulation cover for horizontal RIO chests
- _baskets and dividers
- _Lock for sliding covers
- _Additional mounting options in the form of rivet nuts
- _Frame heating for RIO S



 DIMENSIONS

| RIO S | | 68 | 100 | 125 | 150 | 175 |
|------------------------------|----|-----------|-------------|---------------|---------------|---------------|
| length, exterior / interior | mm | 680 / 530 | 1.000 / 850 | 1.250 / 1.100 | 1.500 / 1.350 | 1.750 / 1.600 |
| depth, exterior / interior | mm | 650 / 500 | 650 / 500 | 650 / 500 | 650 / 500 | 650 / 500 |
| height outside front / rear | mm | 769 / 883 | 769 / 883 | 769 / 883 | 769 / 883 | 769 / 883 |
| stacking height front / rear | mm | 530 / 570 | 530 / 570 | 530 / 570 | 530 / 570 | 530 / 570 |

RIO S

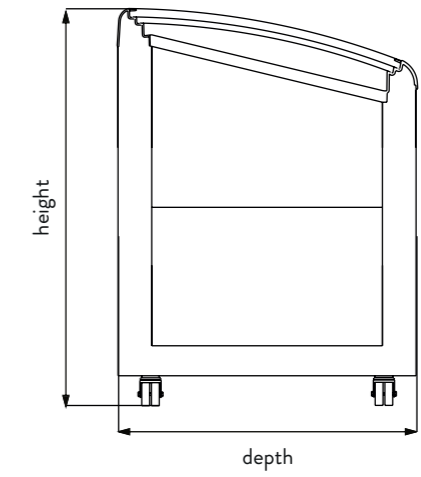
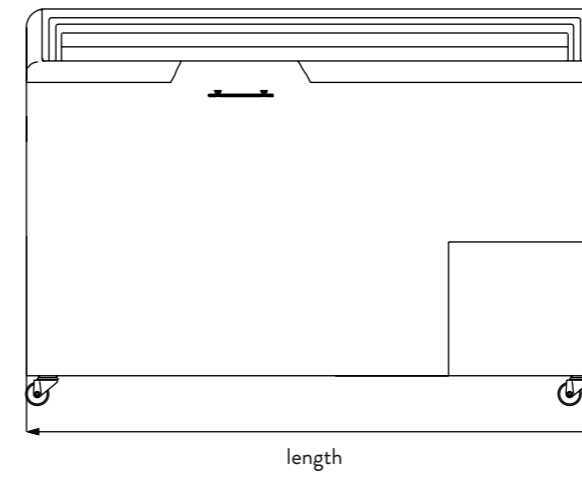

| RIO H | | 68 | 100 | 125 | 150 | 175 |
|-----------------------------|----|-----------|-------------|---------------|---------------|---------------|
| length, exterior / interior | mm | 680 / 530 | 1.000 / 850 | 1.250 / 1.100 | 1.500 / 1.350 | 1.750 / 1.600 |
| depth, exterior / interior | mm | 650 / 500 | 650 / 500 | 650 / 500 | 650 / 500 | 650 / 500 |
| height outside front / rear | mm | 883 / 883 | 883 / 883 | 883 / 883 | 883 / 883 | 883 / 883 |
| stacking height | mm | 610 | 610 | 610 | 610 | 610 |

RIO H

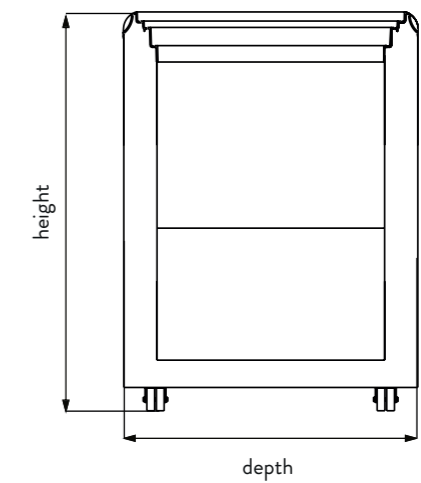
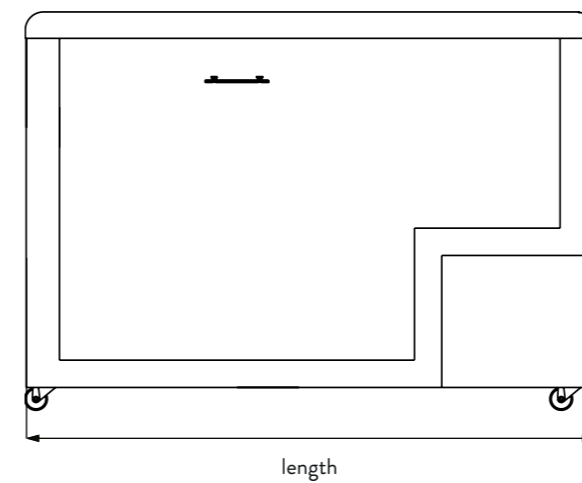

AHT Cooling Systems GmbH
Werksgasse 57
8786 Rottenmann | Austria

t. +43 3614 24 51-0
sales@aht.at
www.aht.at

©AHT Cooling Systems GmbH
Subject to technical changes and typographical errors
Version: 04/2024